

## Galsol

This product combines a 3-way solenoid with the hydraulic body.  
Galsol is suited to numerous applications, including Filtering and computerized irrigation

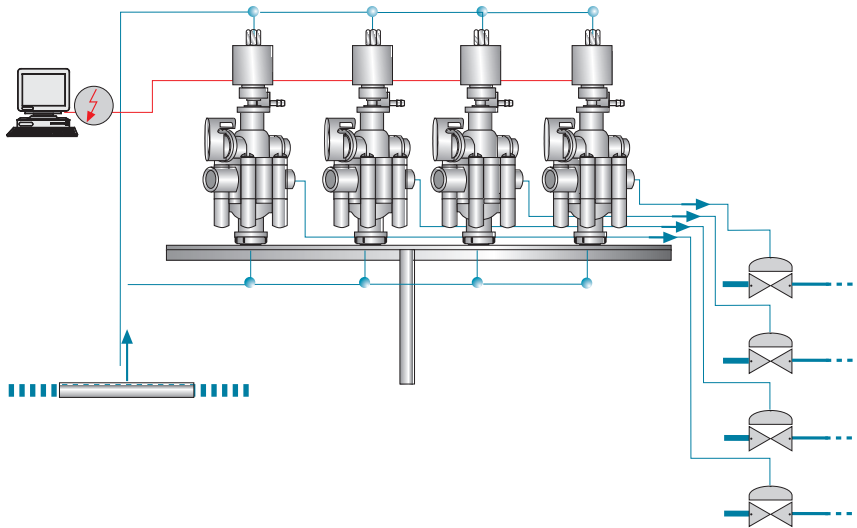

**N.C. Valve**

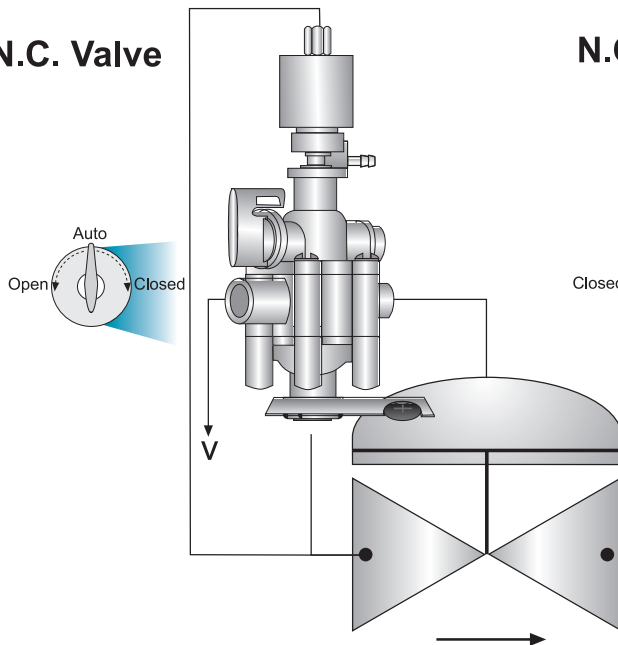

**N.O. Valve**

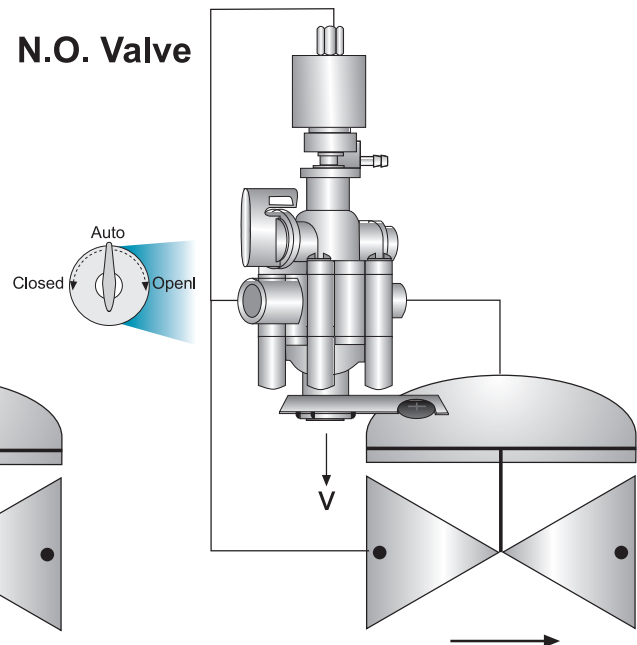

## TECHNICAL DATA

Voltage:	Solenoid	Voltage	Inrush [A]	Holding [A]
Current:	2W50 Hz	V <sup>+10%</sup> n-20%	0.3	0.19
	2W60 Hz		0.2	0.14
	3W50 or 60 Hz		0.125	0.125
	DC		4.5W	

Protection: IP66  
 Ambient Temp: Max 60<sup>0</sup> C  
 Fluid Temp: Max 80<sup>0</sup> C

### Workig Pressure 2W NC

Orifice	up to 2.0
Pressure (bar)	12

### Materials

Housing: Reinforced Nylog 66  
 Plunger and Pole: passivated AIS143OF  
 Rubber Seal: EPDM  
 Encapsulate: Polyurethane

### Workig Pressure 3W NC

Orifice	1.0	1.2	1.6
AC Pressure (bar)	16	11	6
DC Pressure (bar)	12	9	5

### Workig Pressure 3W NO

Orifice	1.0	1.2	1.6
Pressure (bar)	16	12	8

Voltage: 9 or 12 VDC  
 Resistance: 4.2Ω  
 Capacitors: 4700μF for 9VDC, 220μF for 12VDC  
 Switching Time: 25-50 msec  
 Protection: IP66  
 Ambient Temp: Max 60<sup>0</sup> C  
 Fluid Temp: Max 80<sup>0</sup> C

### Workig Pressure 2W NC

Orifice	up to 2.0
Pressure (bar)	12

### Workig Pressure 3W NC

Orifice	1.0	1.2	1.6
AC Pressure (bar)	16	11	6

### Materials

Housing: Reinforced Nylog 66  
 Plunger and Pole: Passivated AIS143OF  
 Rubber Seal: EPDM  
 Encapsulate: Polyurethane

### Workig Pressure 3W NO

Orifice	1.0	1.2	1.6
Pressure (bar)	16	12	8